

U 65/80

Grinding width 300 up to 450 mm with different motor capacities



One grinding head carriage
Rotatable or fixed clamping table



One grinding head carriage two-stationary grinding
e.g. clamping to the left, grinding to the right



Two grinding head carriages for increased output
Segmental- and peripheral grinding



Control desk with screen
CNC-multifunction key-
board integrated machine
control board and electro-
nic handwheel



4 Combined machine with two grinding carriages for segmental- and peripheral grinding. CNC controlled, 11 axes

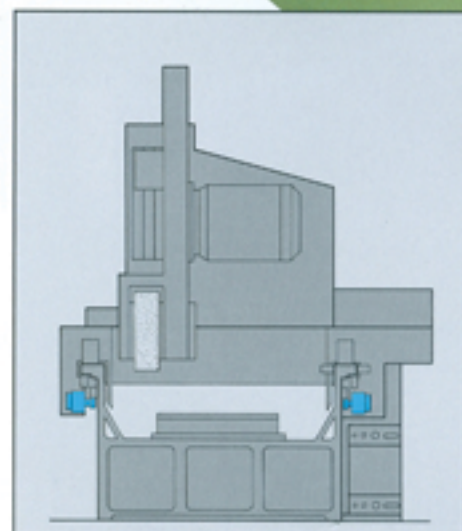

Dual-side drive synchronized

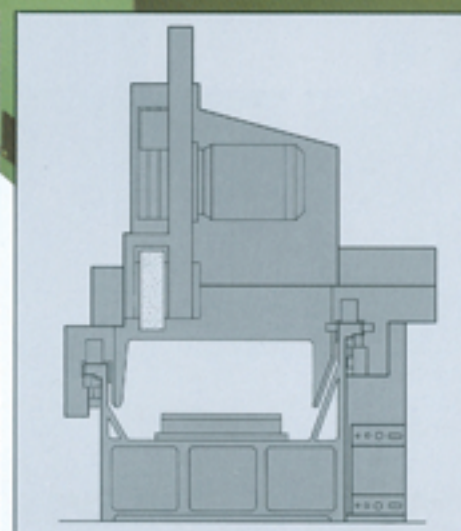

Version for increased clearance

- 9 Coolant device
- 11 Machine control
- 6 Grinding motor
- 5 Infeed device for grinding tool
- 4 Grinding head carriage
- 2 Guideways
- 7 Grinding tool
- 8 Traverse drive
- 3 Machine table
- 1 Machine bed
- 10 Electrical system

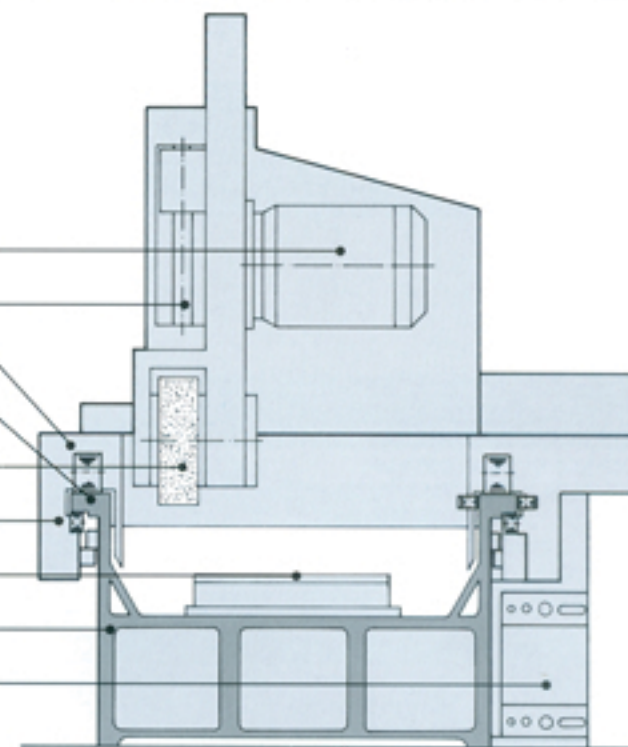

Technical data

Machine type	U 65/		U 80/		U 100/			U 130/			U 150/			
	350	350	500	600	350	500	600	350	500	600	350	500	600	
Grinding wheels	∅	350	350	500	600	350	500	600	350	500	600	350	500	600
	max. width mm	75	75	125	150	75	125	150	75	125	150	75	125	150
Grinding motor	kW	15	15	30	45	15	30	45	15	30	45	15	30	45
		Clearance	height mm	260	260	300	350	260	300	350	260	300	350	260
Clearance	width mm	530		660		850		1150		1350				
	Grinding width mm	300												
		400												
		450												
		500												
		600												
		800												
		900												
		1000												
		1100												
Grinding length	mm	1700 – 15000												
Carriage speed		(0,02) 0,5 – 40 m/min												